

Noise spectrum referring to max efficiency of 20° curve  
 Variation of +/- 3 db(A) on total range of performance

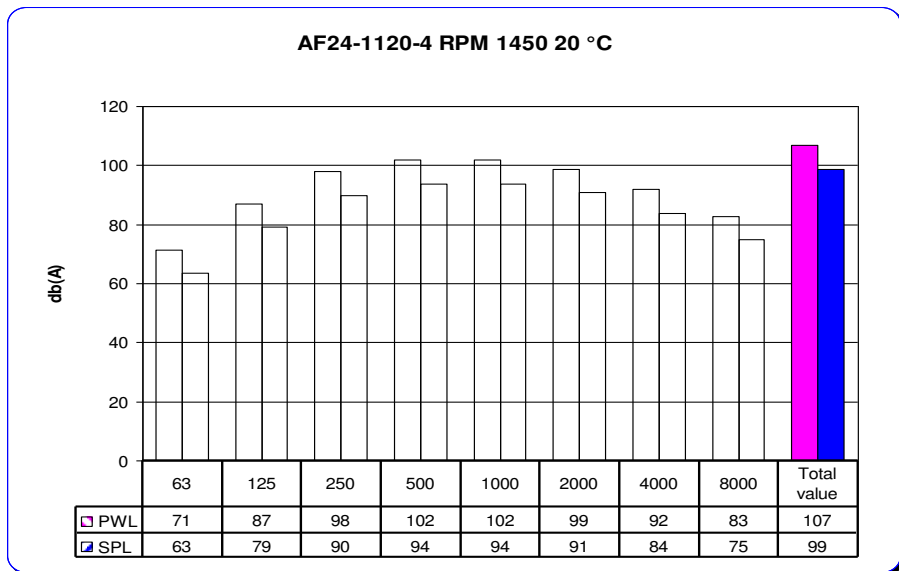

Noise spectrum referring to max efficiency of 20° curve  
 Variation of +/- 3 db(A) on total range of performance

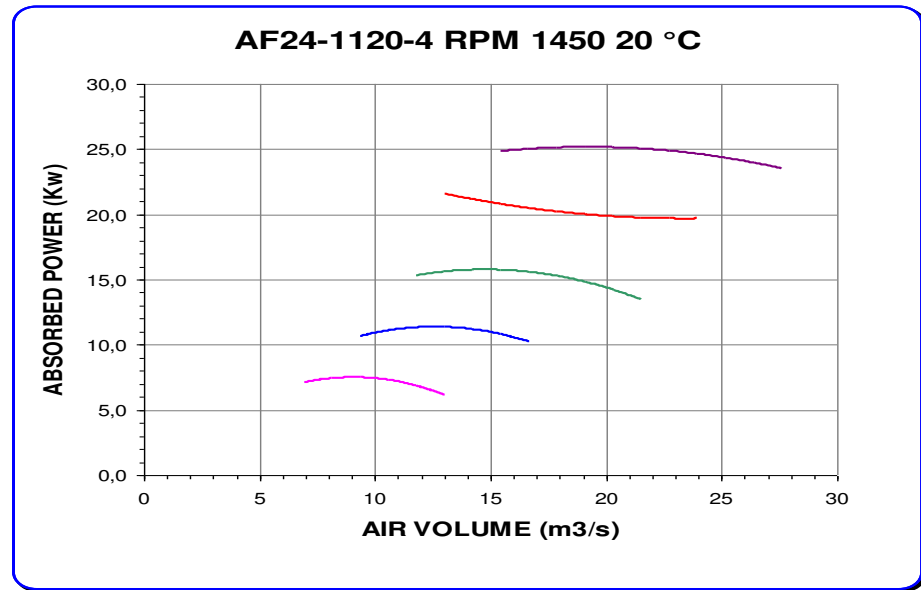
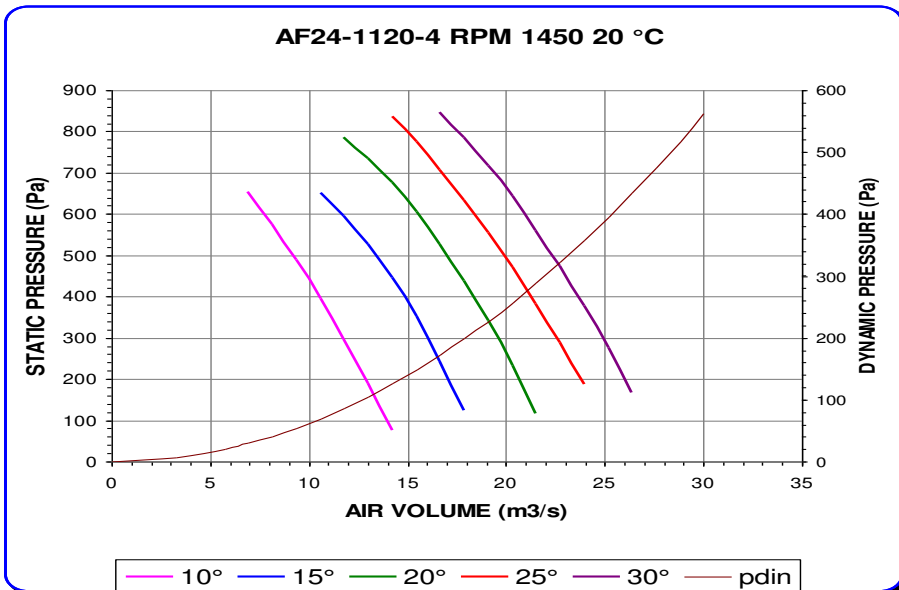
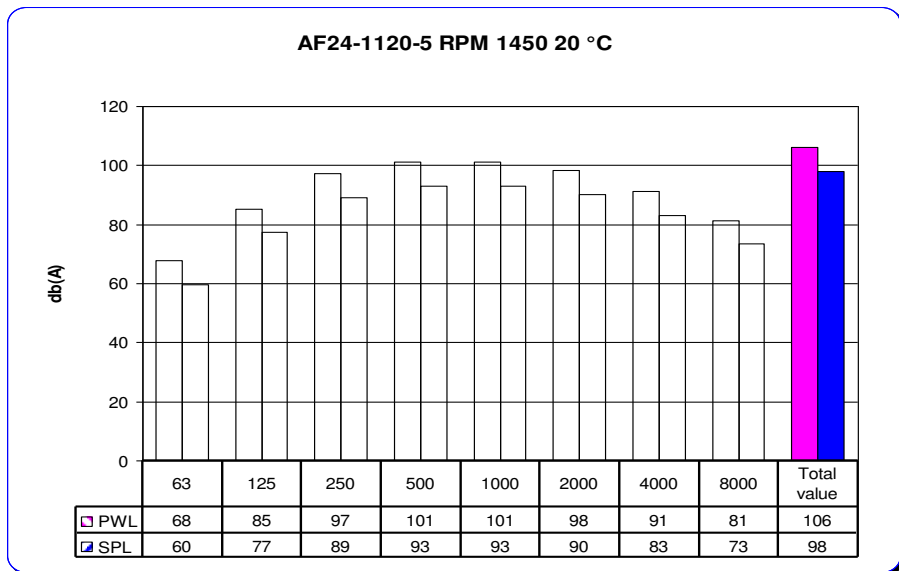
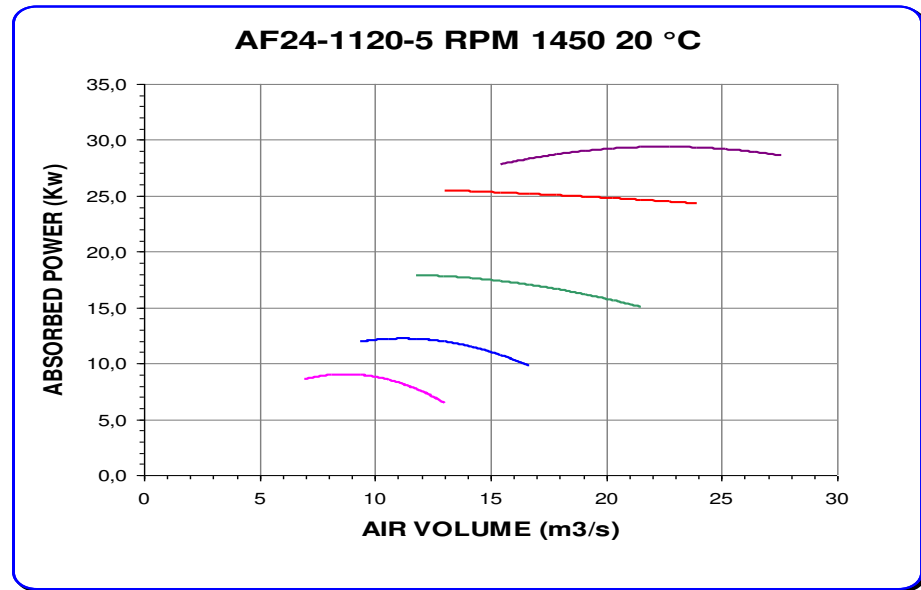
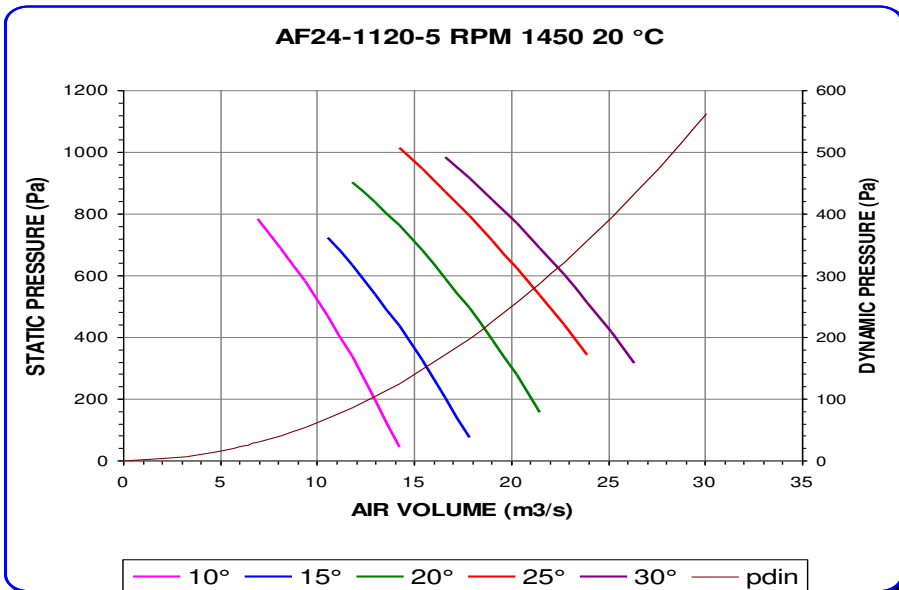

Noise spectrum referring to max efficiency of 20° curve  
 Variation of +/- 3 db(A) on total range of performance

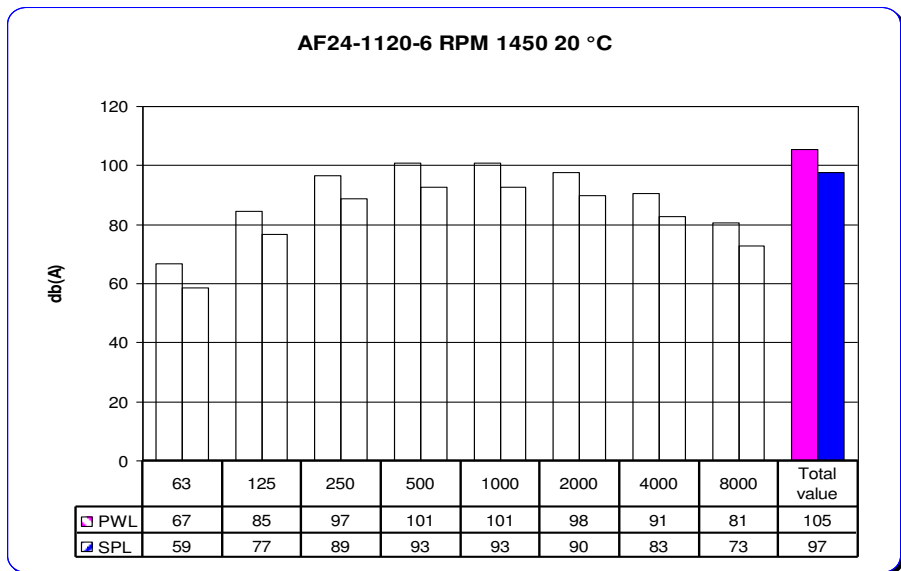
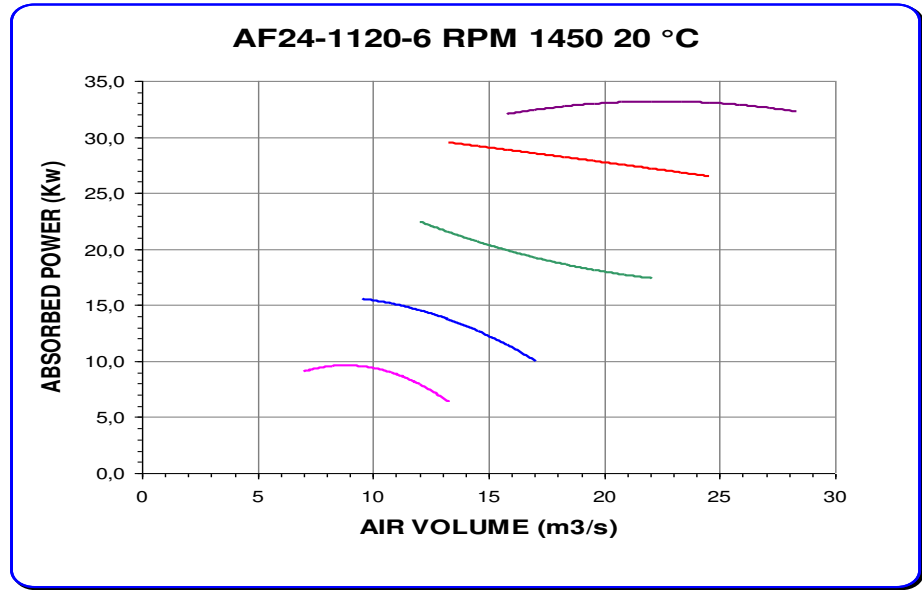
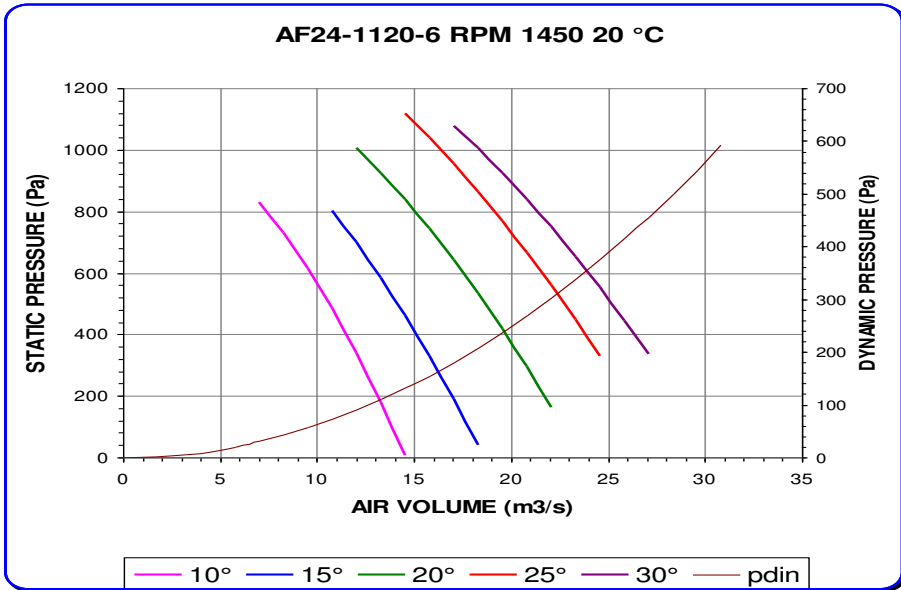

Noise spectrum referring to max efficiency of 20° curve  
 Variation of +/- 3 db(A) on total range of performance

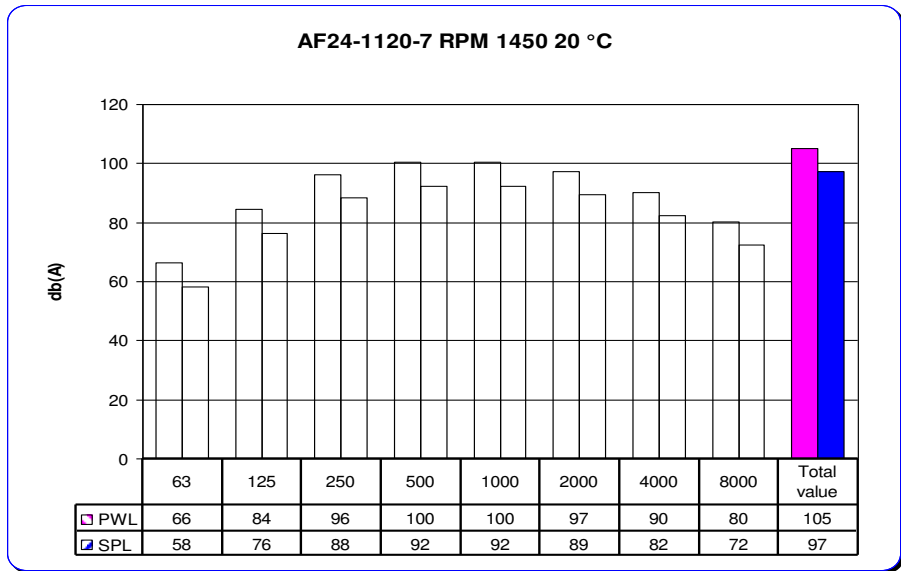
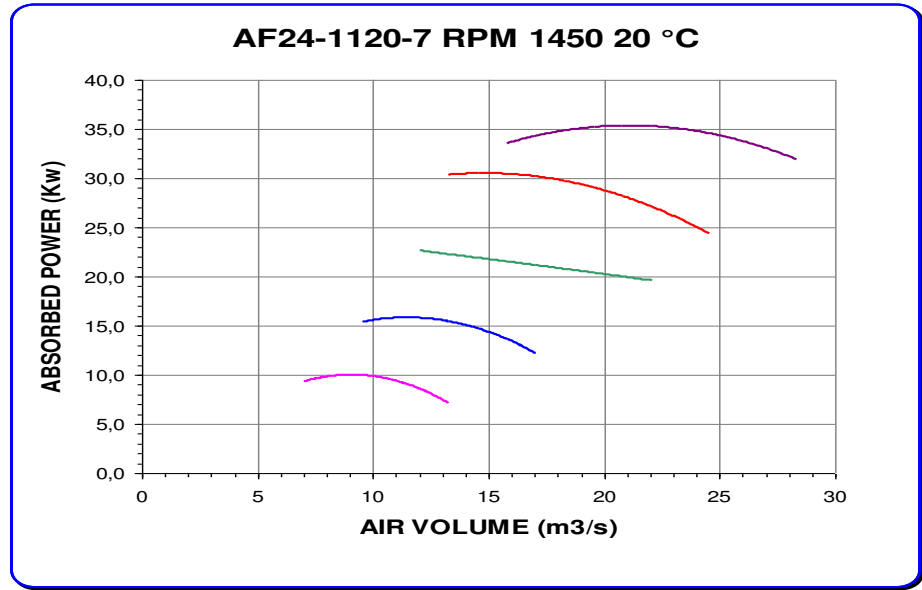
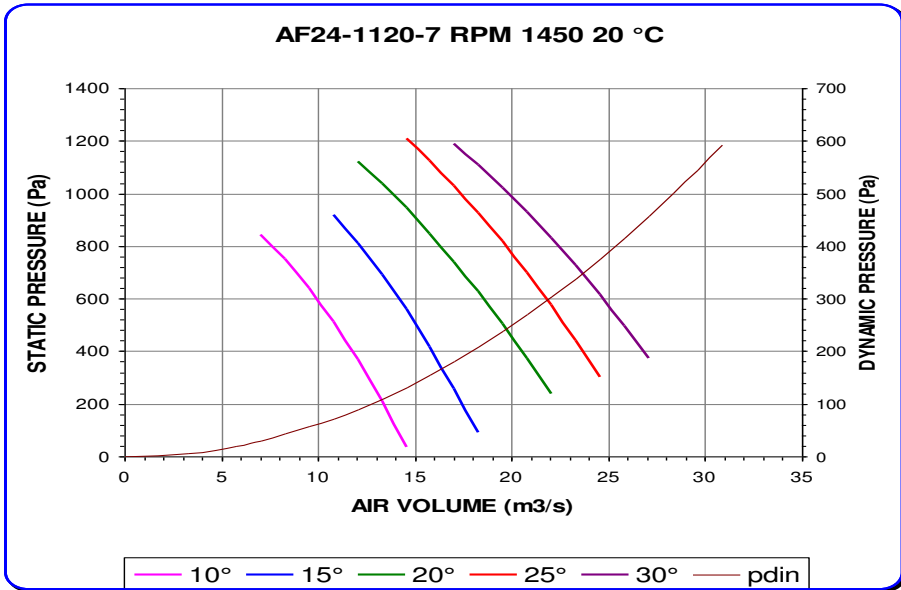

Noise spectrum referring to max efficiency of 20° curve  
 Variation of +/- 3 db(A) on total range of performance

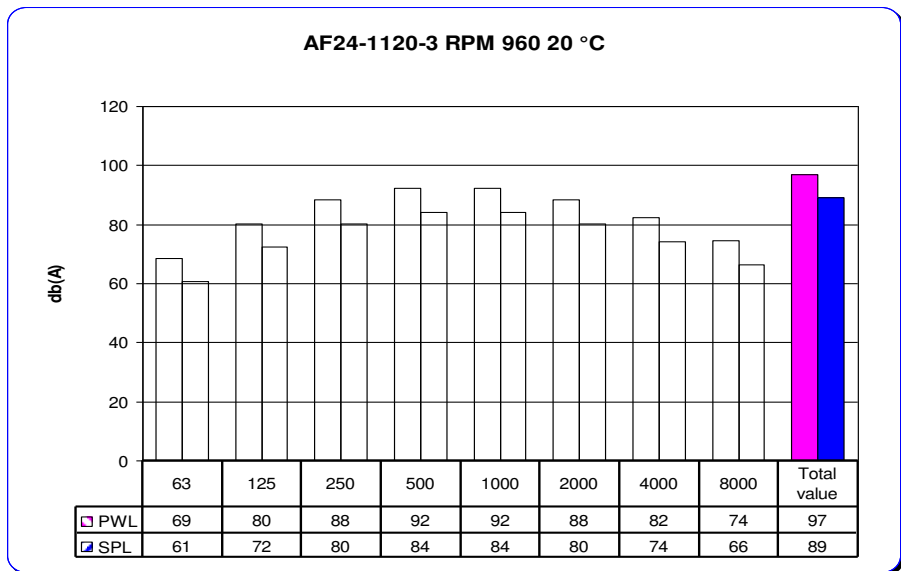
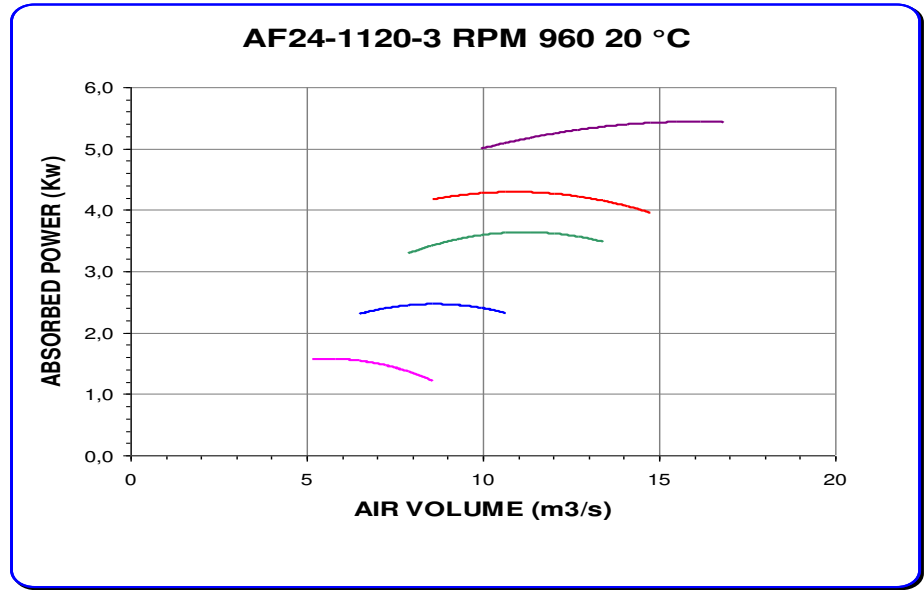
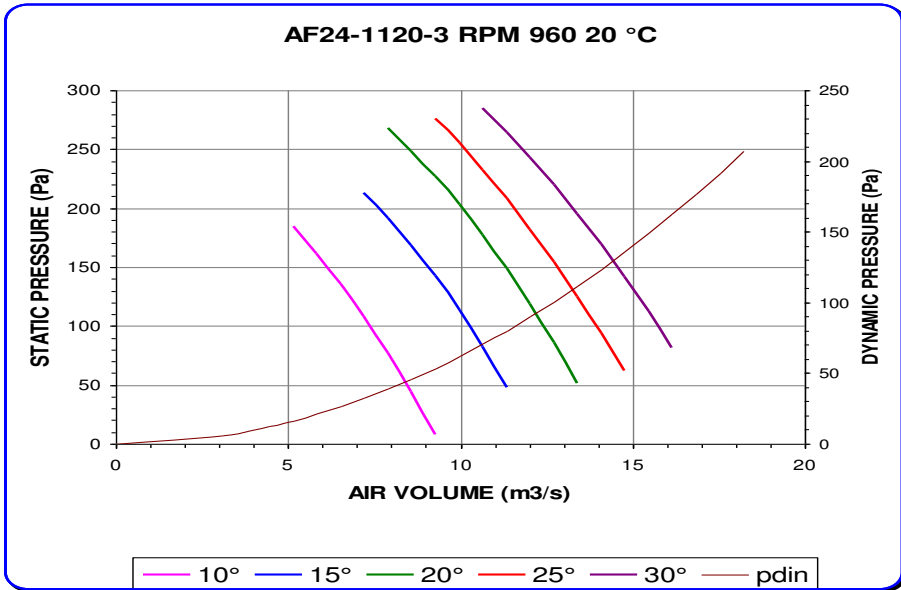

Noise spectrum referring to max efficiency of 20° curve  
 Variation of +/- 3 db(A) on total range of performance

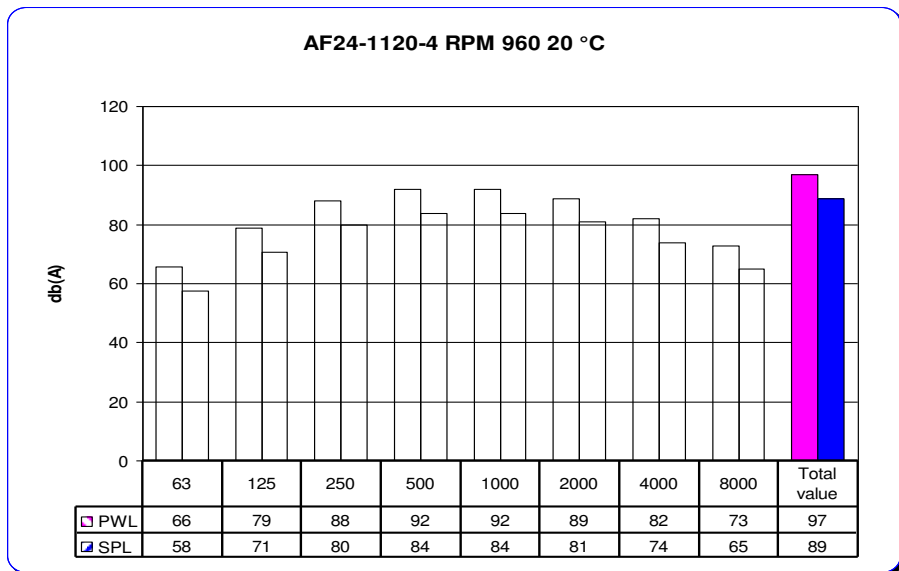
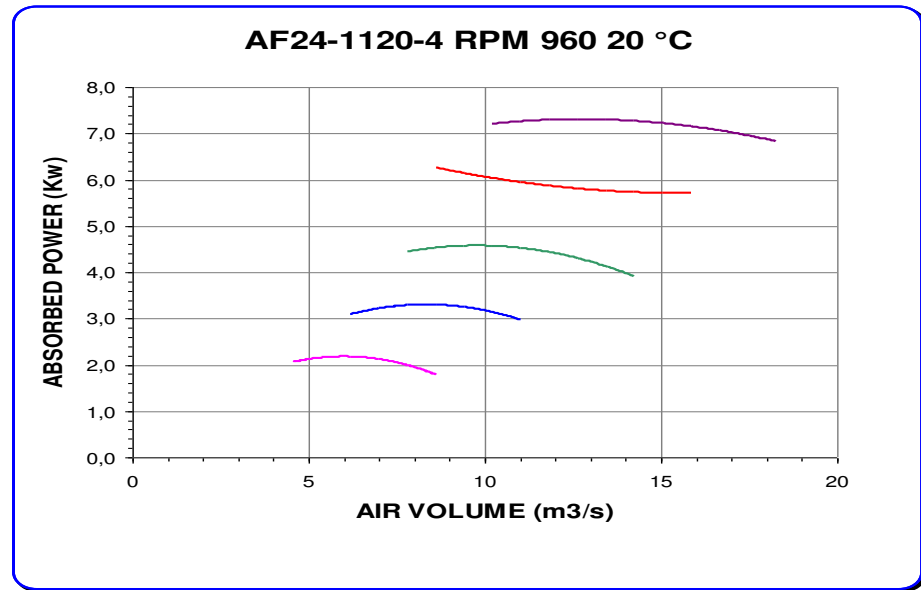
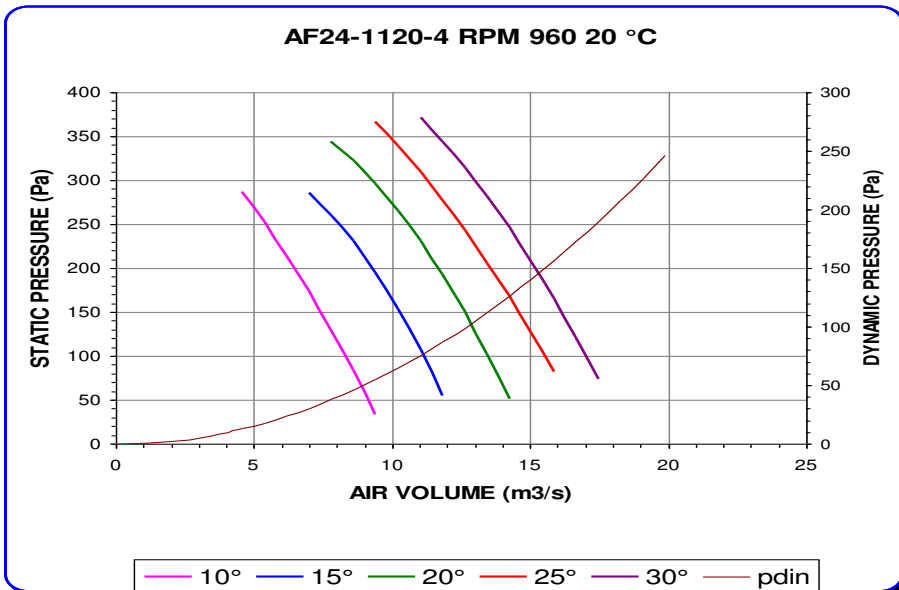

Noise spectrum referring to max efficiency of 20° curve  
 Variation of +/- 3 db(A) on total range of performance

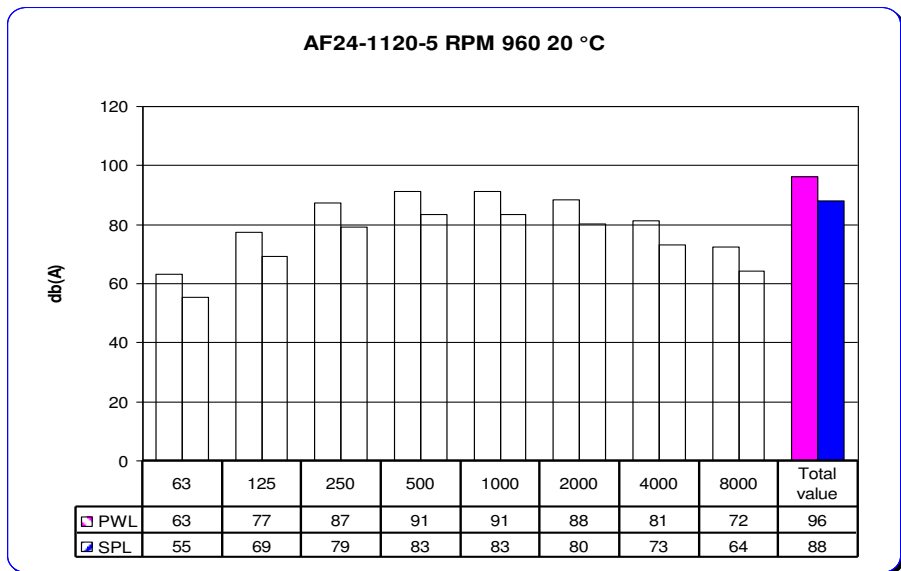
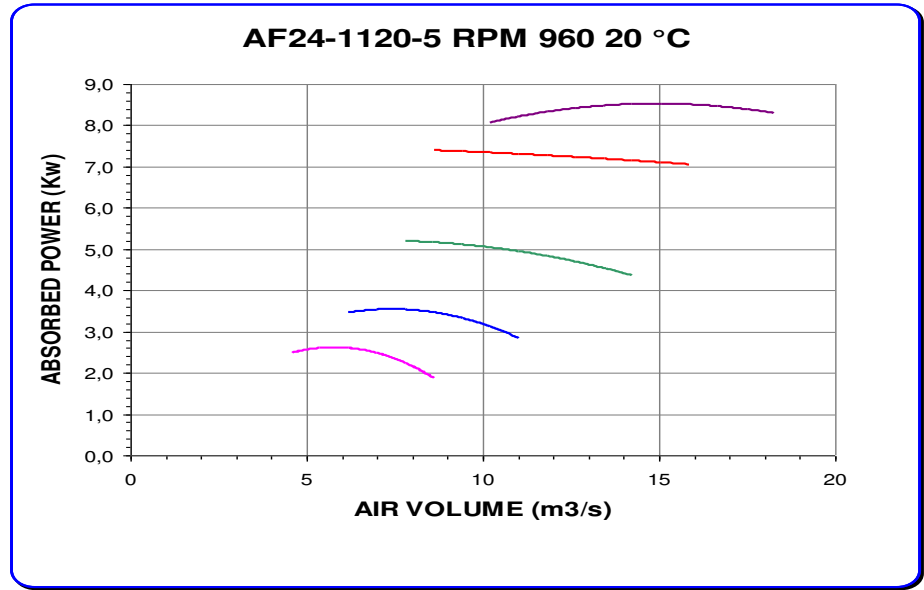
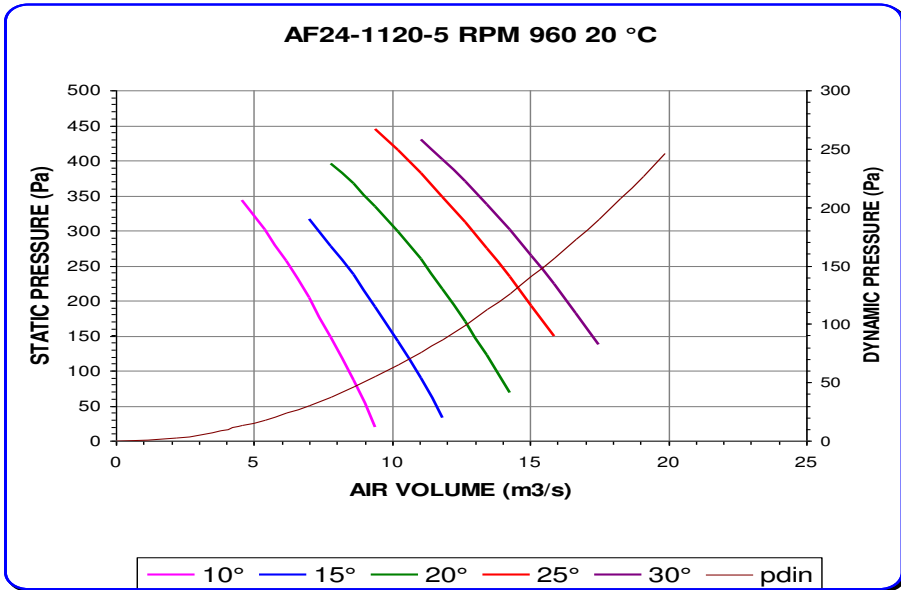

Noise spectrum referring to max efficiency of 20° curve  
 Variation of +/- 3 db(A) on total range of performance



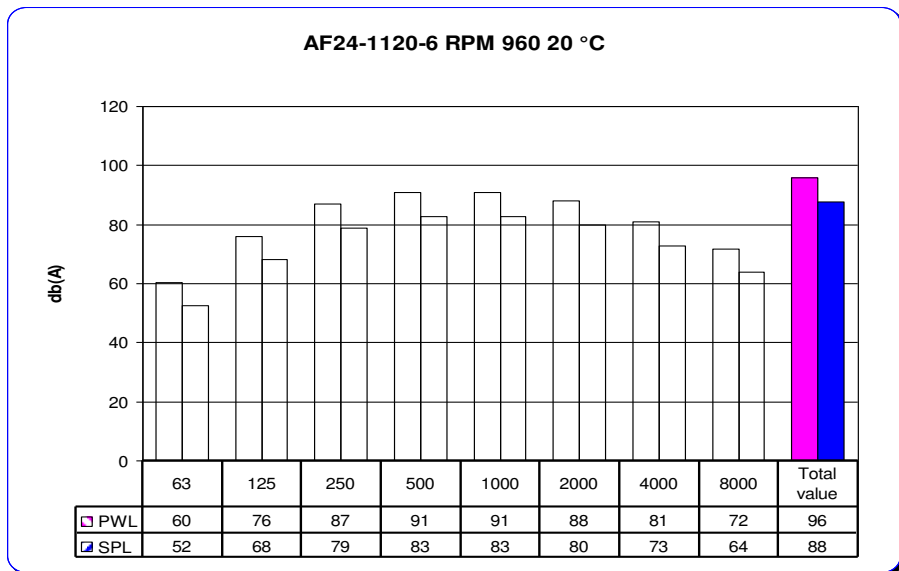
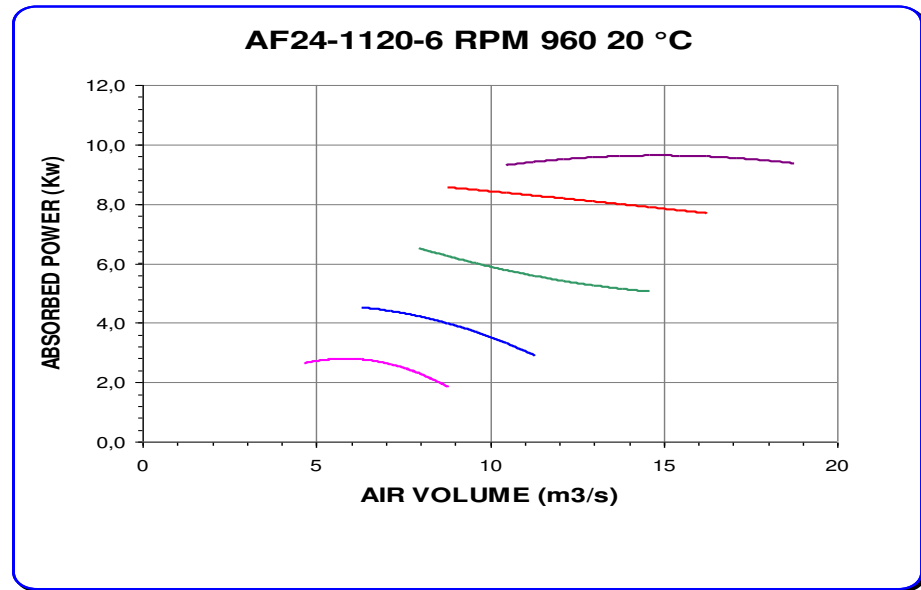
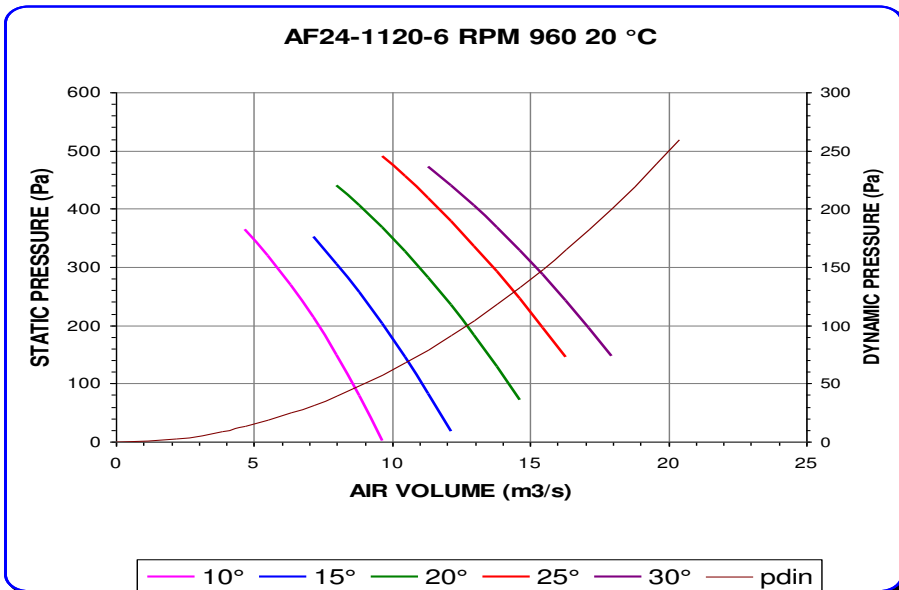

Noise spectrum referring to max efficiency of 20° curve  
 Variation of +/- 3 db(A) on total range of performance

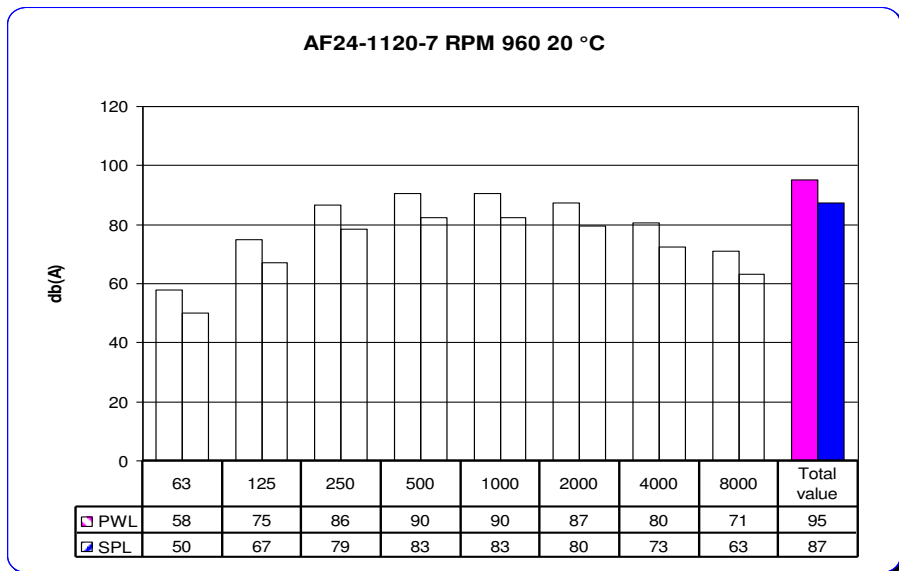
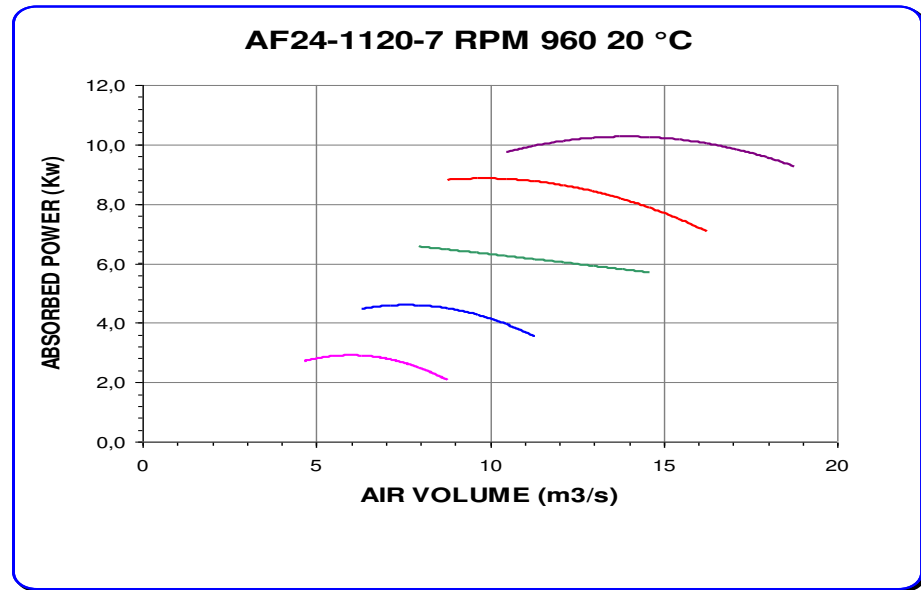
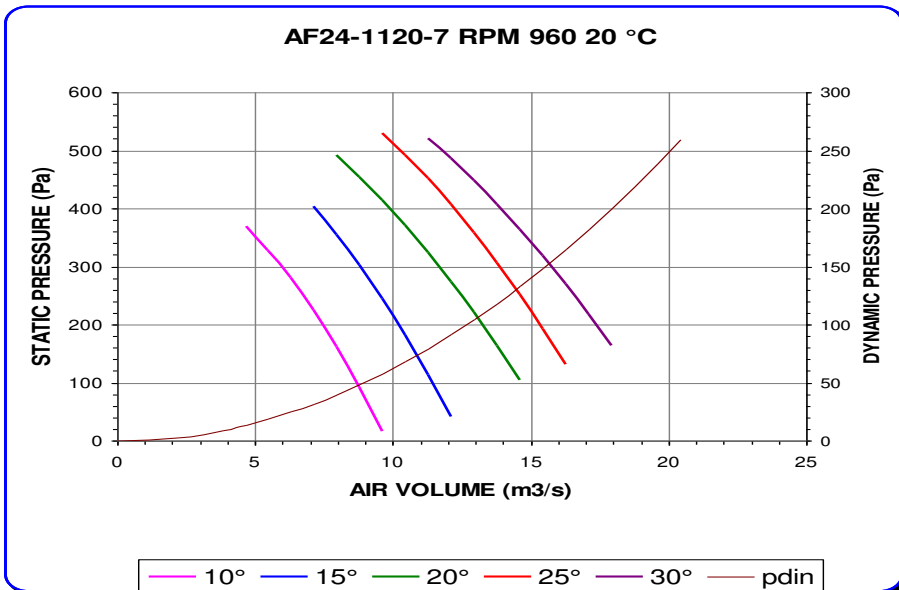

Noise spectrum referring to max efficiency of 20° curve  
 Variation of +/- 3 db(A) on total range of performance

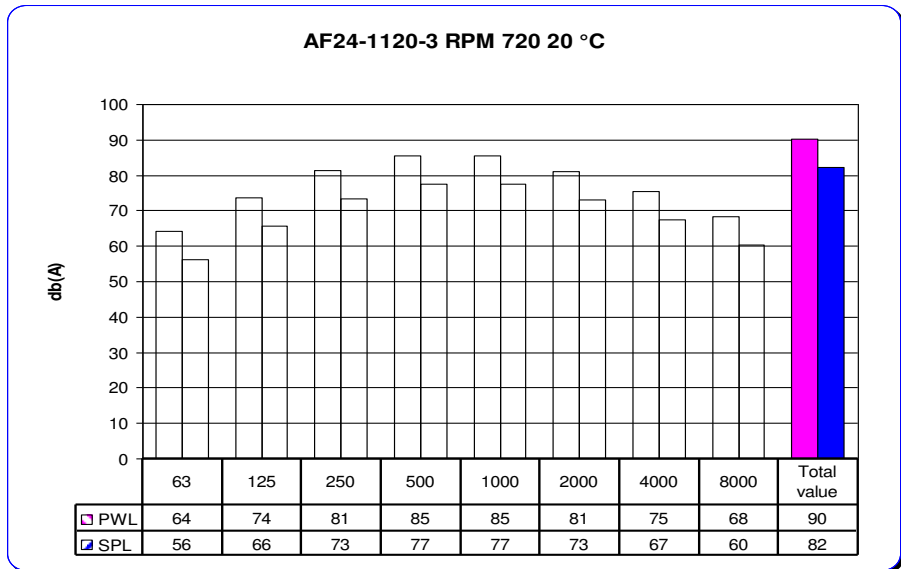
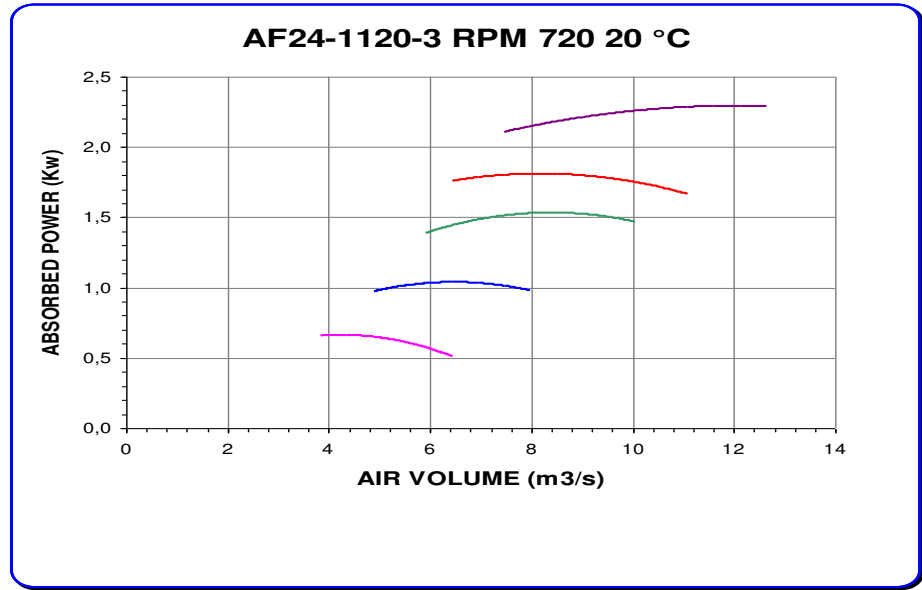
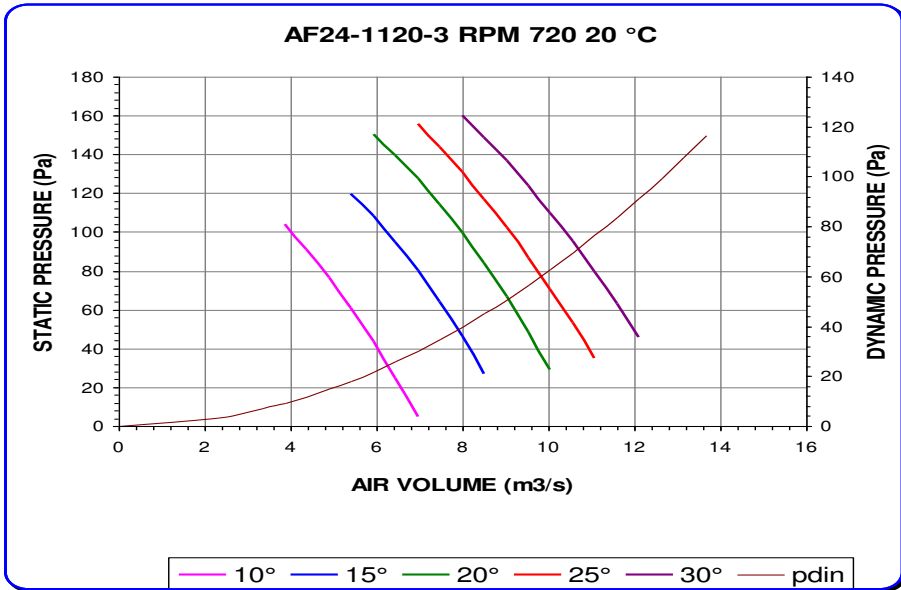

Noise spectrum referring to max efficiency of 20° curve  
 Variation of +/- 3 db(A) on total range of performance

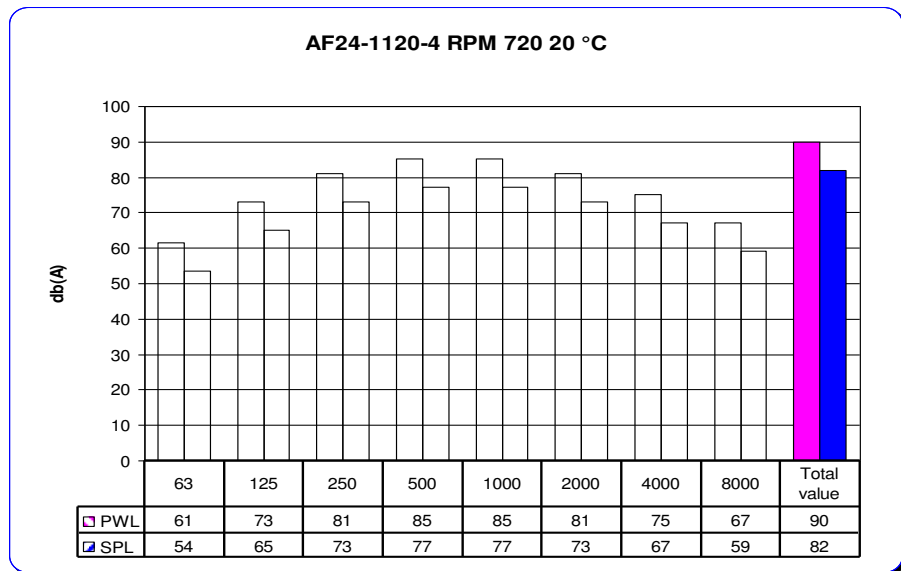
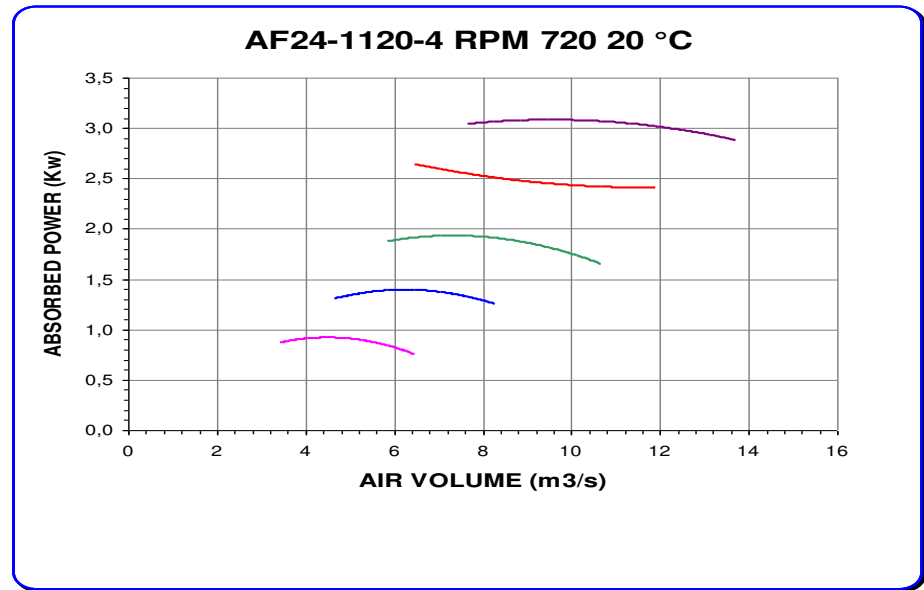
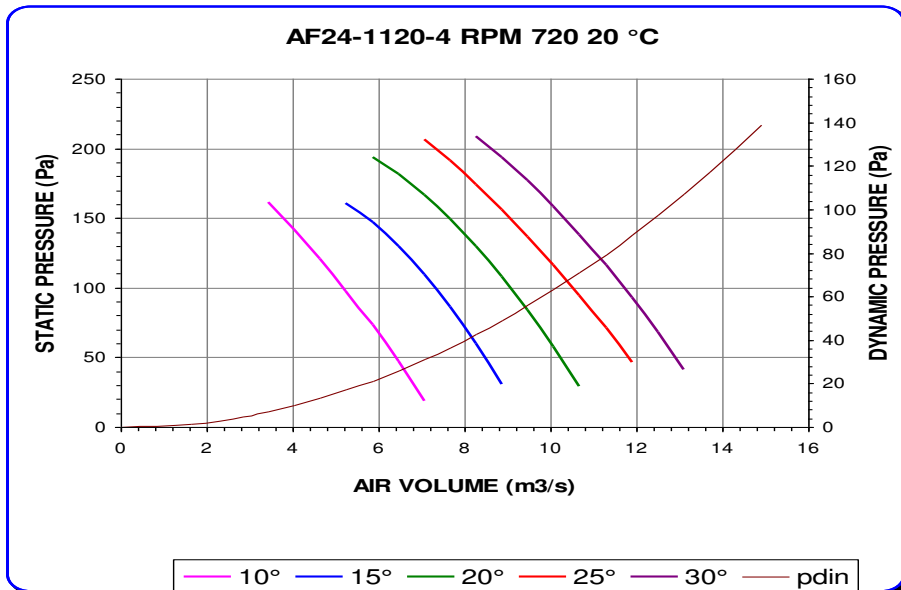

Noise spectrum referring to max efficiency of 20° curve  
 Variation of +/- 3 db(A) on total range of performance

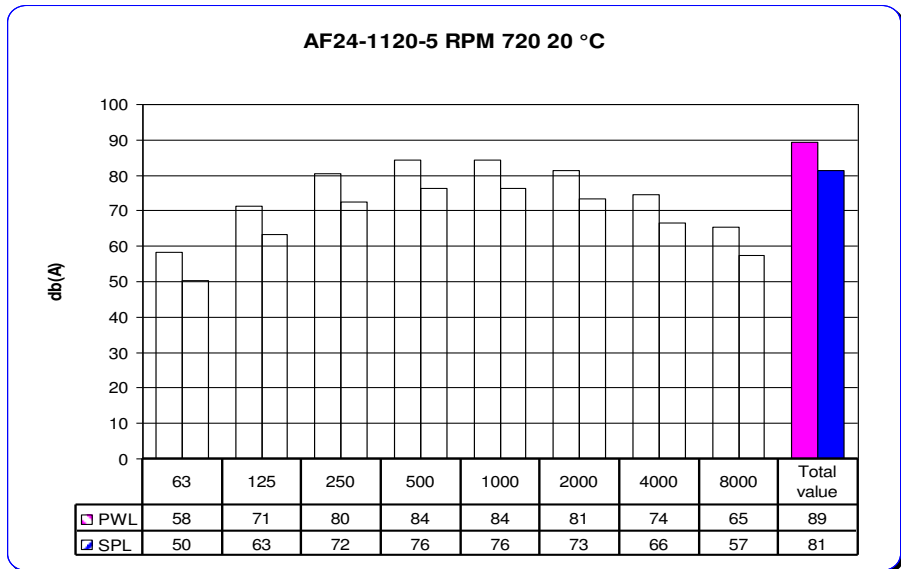
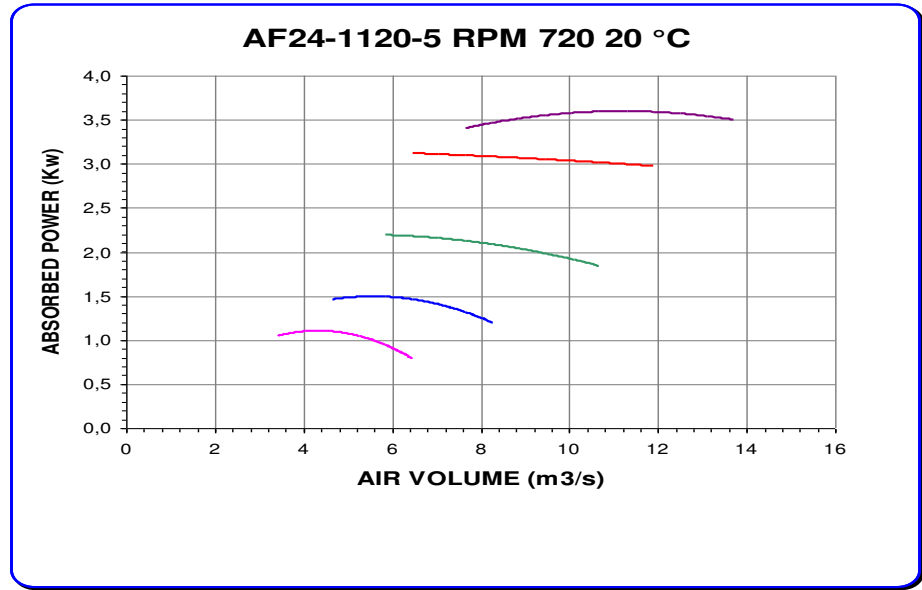
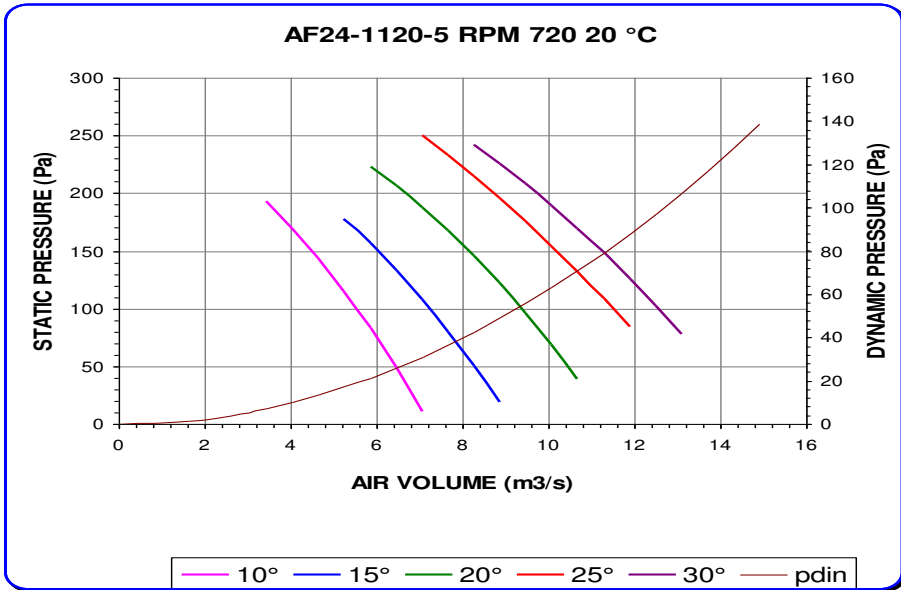

Noise spectrum referring to max efficiency of 20° curve  
 Variation of +/- 3 db(A) on total range of performance

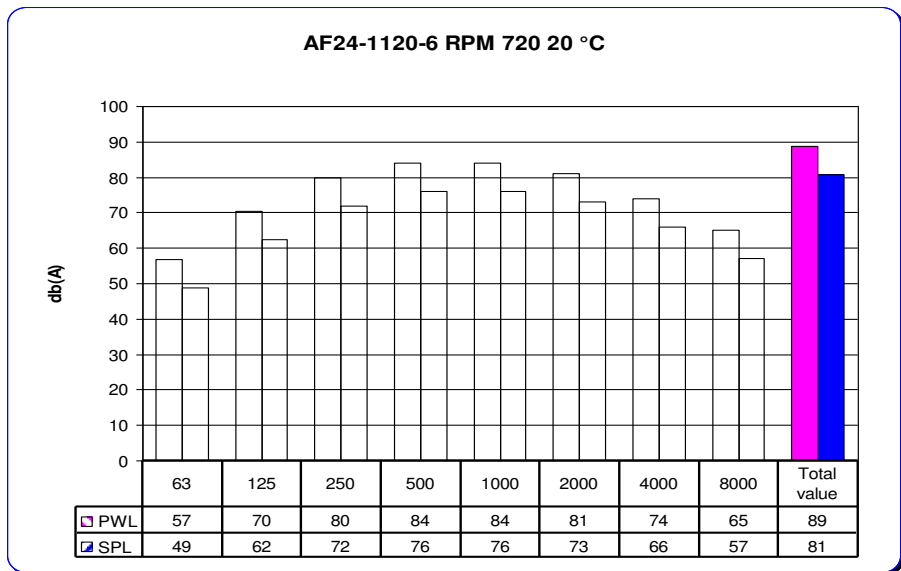
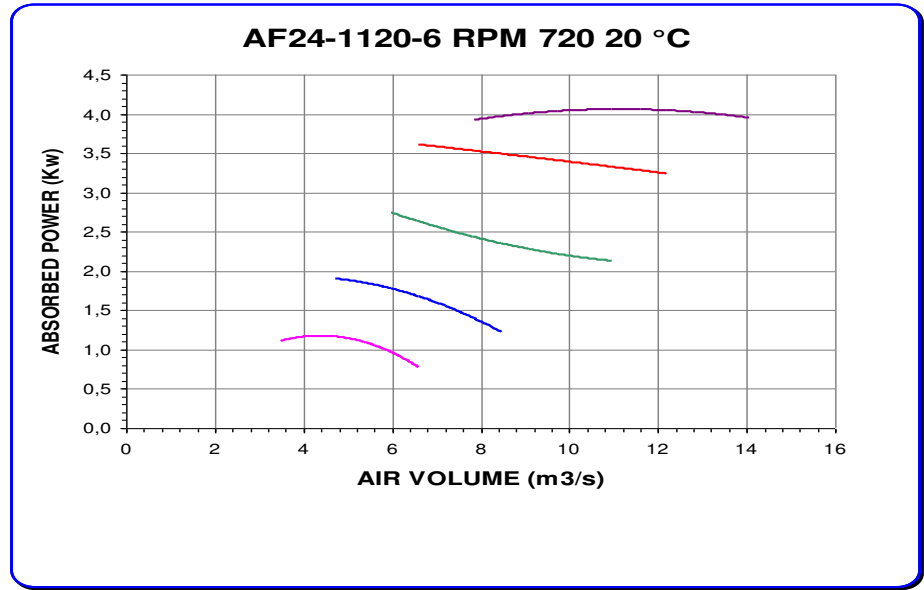
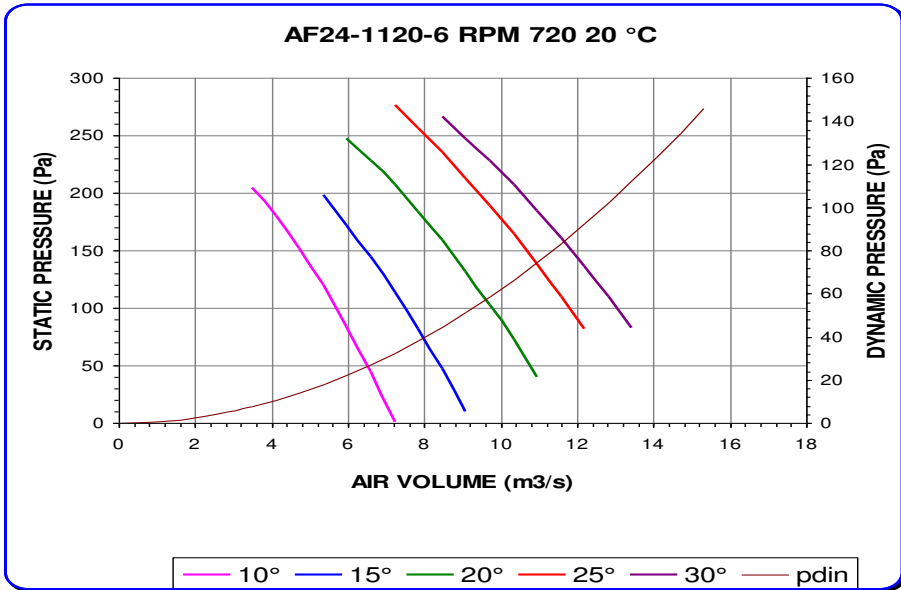

Noise spectrum referring to max efficiency of 20° curve  
 Variation of +/- 3 db(A) on total range of performance

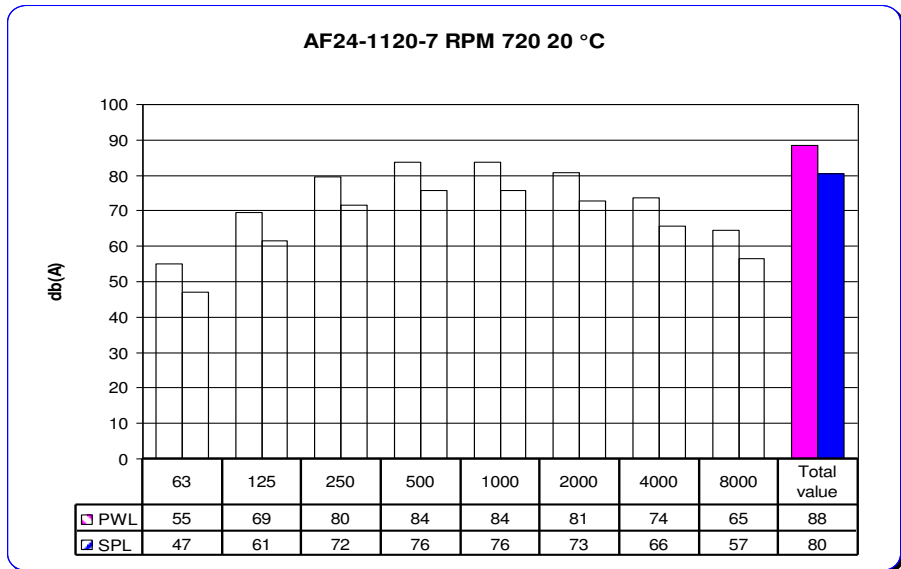
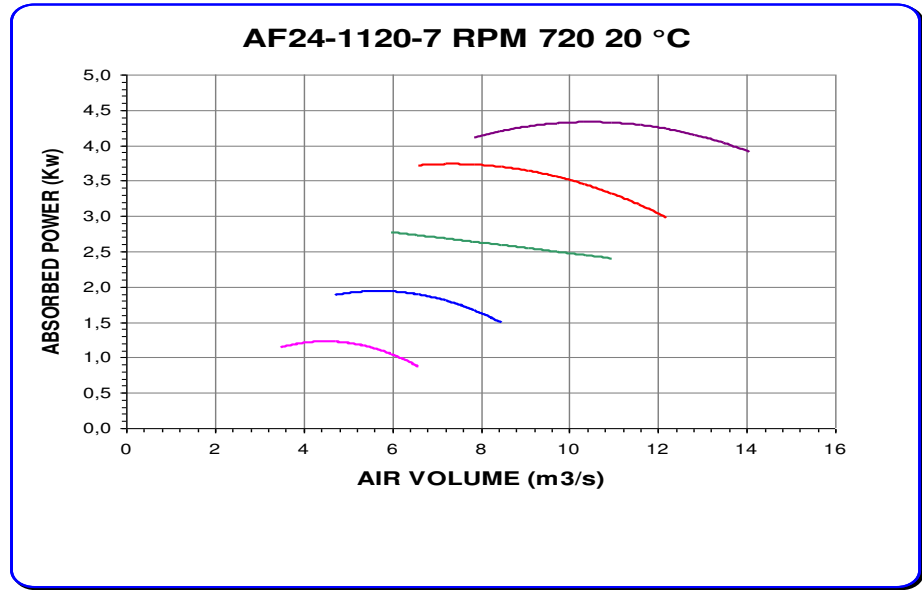
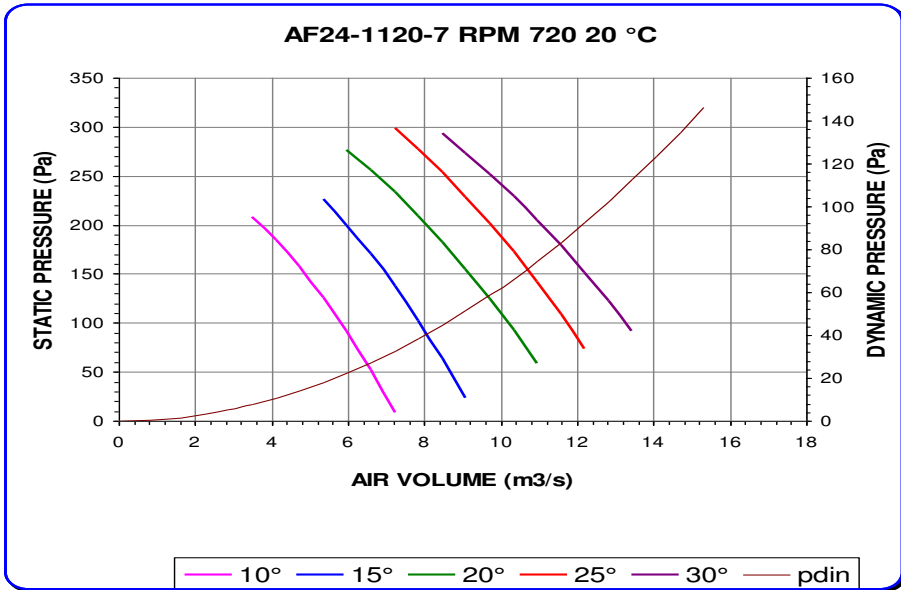

Noise spectrum referring to max efficiency of 20° curve  
 Variation of +/- 3 db(A) on total range of performance

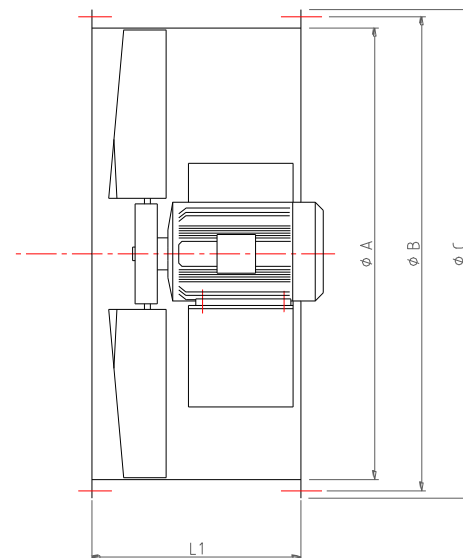
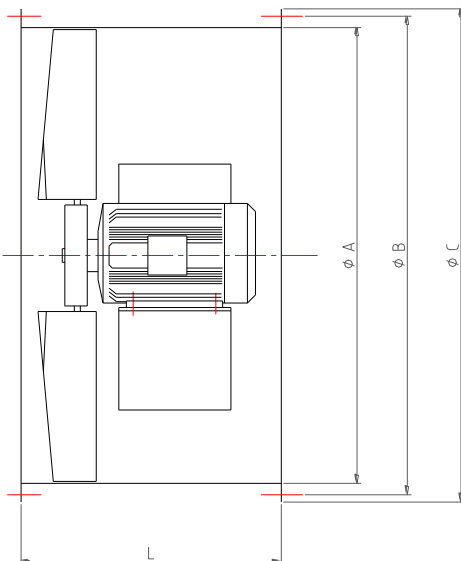
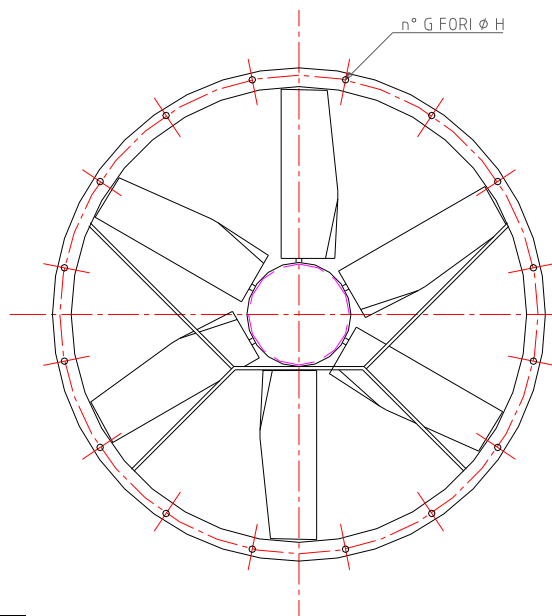

**Φ 1120**

Grandezza Motore	A	B	C	L	L1	G	H	Peso medio con cassa L Kg.	Peso medio con cassa S Kg.
100 112	1120	1190	1230	500	350	16	15	153 160	117 220
132	1120	1190	1230	600	450	16	15	206	166
160 180	1120	1190	1230	800	600	16	15	297 360	263 326
200 225	1120	1190	1230	950	-	16	15	492 517	-